

CAD FILE:

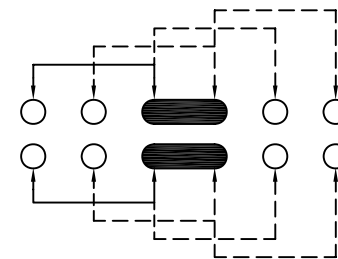

SCHEMATIC (SHORTING)

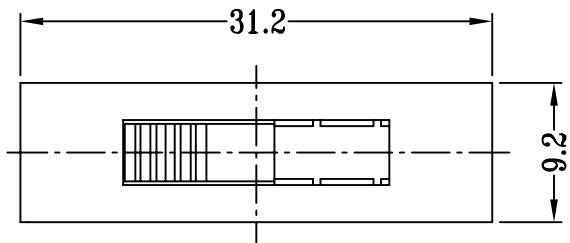
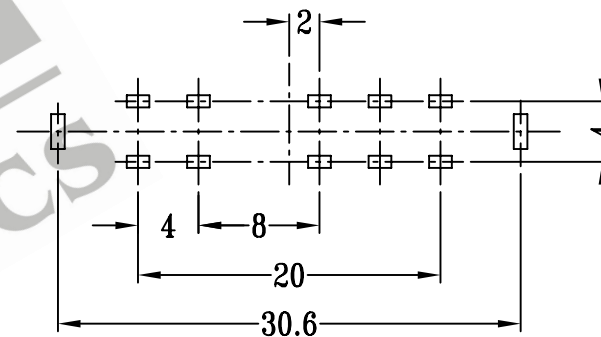
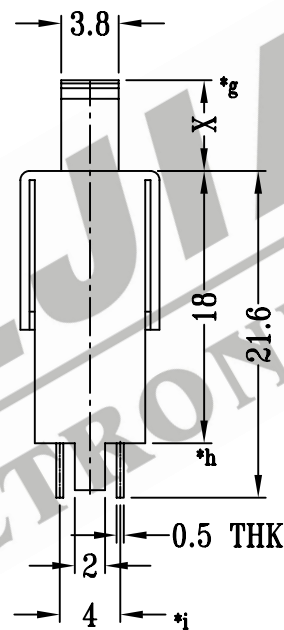
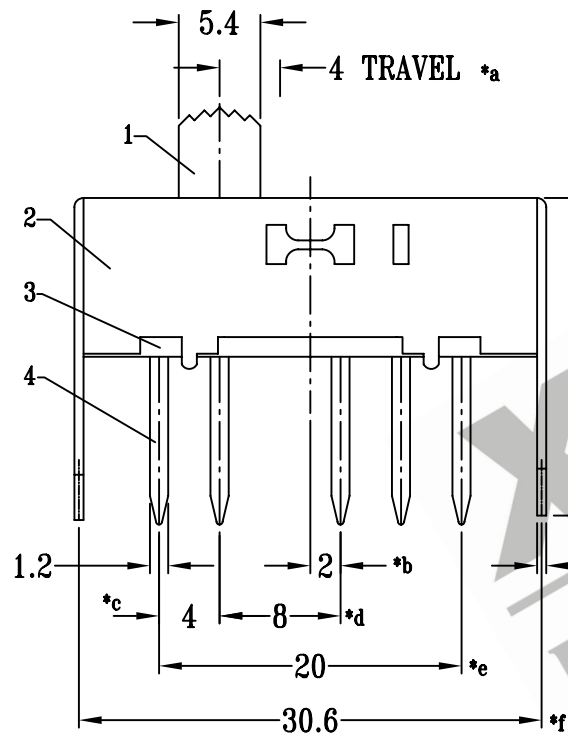

P.C.B LAYOUT

注:带"*"表示关键尺寸(9个)

NO.	PARTS	MATERIALS	Q'TY	FINISH	TOLERANCE UNLESS SPECIFIED	SHENZHEN XIEJIA ELECTRONICS CO.,LTD.					
8						TITLE : VERTICAL SLIDE SWITCH		UNIT : mm	DRWG NO.: XJ-DR-SS24H08-00		
7	CONTACT CLIP	PBS STRIP	2	Ag PLATED		MODEL: SS-24H08		SCALE: 2:1	DWN.	ZHOUYU	2003-5-24
6	SPRING	STEEL WIRE	1	TEMPER	WITHIN: 1.5±0.1mm OVER : 1.5±0.2mm				CHK'D	FANGYING	2003-5-24
5	STEEL BALL	STEEL	2	NATURAL					APPD.	KANGXINAN	2003-5-24
4	TERMINAL	BRASS STRIP	10	Ag PLATED OVER Ni PLATED					ALL MATERIALS MUST BE COMPLIANT TO ROHS		
3	BASE	PHENOLIC RESIN	1	BLACK							
2	FRAME	STEEL STRIP	1	Ni PLATED							
1	KNOB	POM	1	BLACK							